

ALL PROPRIETARY RIGHTS RESERVED BY TOOLING 2000. THIS DRAWING SHALL NOT BE REPRODUCED OR IN ANY WAY UTILIZED FOR THE MANUFACTURE OF THE COMPONENT OR UNIT HEREIN DRAWN & MUST NOT BE RELEASED TO OTHER PARTIES WITHOUT WRITTEN CONSENT. INFRINGEMENT WILL BE LEGALLY PURSUED.

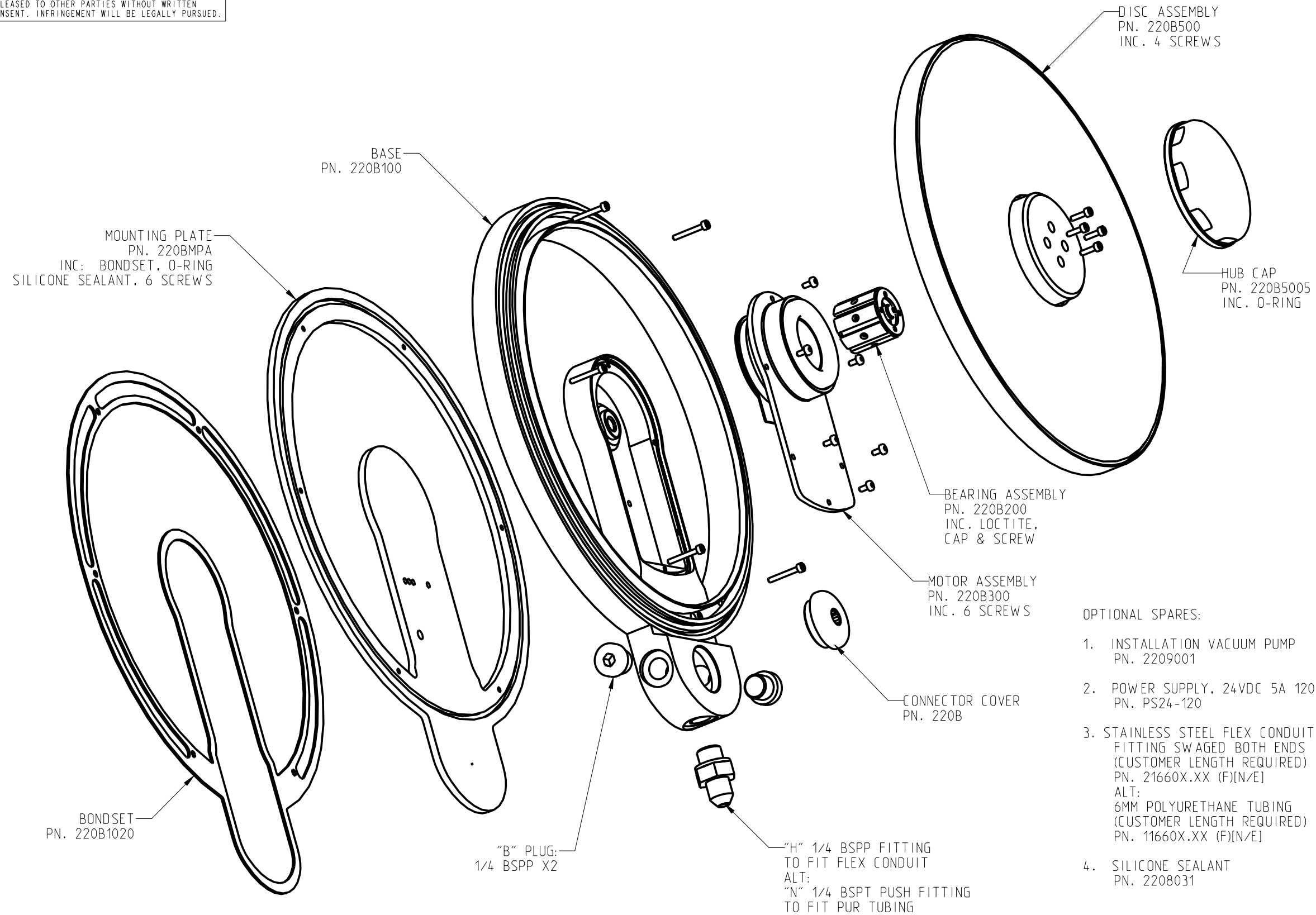

SCALE 0.750

				VP 220B		TOOLING 2000		
				ASSY	CWS	XX.XX.02	220B EXPLODED	
				NONE	WB	XX.XX.02		
					WB	XX.XX.02	PROJ: E:\MODELS\12K1\VP\220B	
A	PRODUCTION	08.11.03	CWS		--	XX.XX.02		
REV	DESCRIPTION	DATE	INT	XX.XX.02	ANGLE	±1°		
							C	VP 220B
								A